

# ViLane Cylindrical Speed Gate CSG301

Elegant Swing Barrier | Compact Design | High-Speed Operation

The ViLane CSG301 is a premium cylindrical swing barrier gate designed for secure and aesthetic pedestrian access control. With its compact footprint, silent operation, and customizable barrier wings, the CSG301 is ideal for corporate lobbies, data centers, transportation hubs, and high-end residential complexes.

The gate supports both single-lane and dual-lane configurations, allowing flexible deployment for narrow or wide passageways. Its modular design enables seamless integration with access control systems, biometric readers, and emergency override protocols.

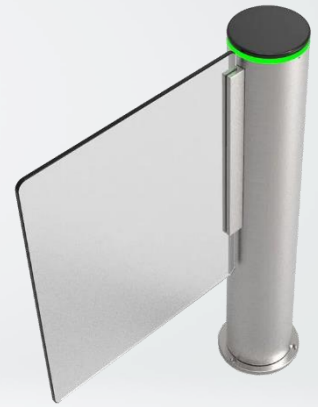

## MAIN FEATURES

- **Advanced Control Logic:** Internal controller with configurable parameters (opening/closing speed, delay time, passage direction, emergency mode).
- **High Security:** Integrated with multiple anti-intrusion technologies and anti-pinch.
- **Bidirectional Passage:** Supports entry and exit in both directions with configurable logic (single pass, multi-pass, visitor modes) and typically programmable (single or dual directional pass) based on requirement.
- **Silent Operation:** Low-noise motor and smooth swing mechanism for quiet environments, around < 50dB.
- **Forced Passage Protection:** Any attempt to push or force the barrier panels without authorization triggers an audible buzzer alarm and red LED warning, ensuring deterrence and immediate operator awareness.
- **Door/Gate Status Monitoring:** Provides a dedicated output signal indicating real-time gate status (open/closed), enabling integration with access control, BMS, or security platforms.
- **Multi-Point Infrared Sensors (Optional):** Available as an upgrade for enhanced presence detection and anti-tailgating/reverse entry monitoring.
- **Radar Sensor (Optional):** Advanced module that complements IR detection, improving presence sensing and fraud detection in high-traffic environments.
- **LED Guidance System:** Integrated LED strips on the top cover indicate gate status (green = authorized, red = denied, blue = standby). Colors can be customized to match corporate identity.
- **Installation & Maintenance:** Adjustable base plates for uneven floors, concealed locks for side panels, and easy access to the control board and motor. Built-in diagnostic software supports on-site testing and troubleshooting.
- **Customizable Barrier Wings:** Choice of tempered glass or perforated acrylic for enhanced airflow and reduced torque resistance.
- **Super Capacitor:** Ensure uninterrupted operation with our free power package, enabling emergency automatic one-time opening of the speed gate.
- **Brushless Servo Motor:** ViLane CSG301 is equipped with a high-performance brushless servo motor that ensures precise control of barrier movement, soft start/stop transitions, and rapid response to access signals. Its encoder-based feedback system enables accurate position tracking, supports forced passage detection, and contributes to long-term reliability with minimal maintenance.

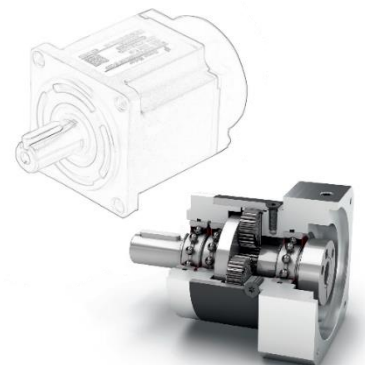

## SPECIFICATIONS

PARAMETER	SPECIFICATION
PASSAGE WIDTH	60 cm single unit ~ 180 cm dual unit (Tempered glass)
HOUSING MATERIAL	SUS304 stainless steel, Thickness 2.4 mm
HOUSING FINISH	Hairline stainless steel (optional powder coat)
BARRIER MATERIAL	10 mm tempered glass (standard), optional acrylic
BARRIER HEIGHT	100 cm (std), up to 120 cm (glass), up to 2000 mm (perforated acrylic)
OPERATION MODES	Barriers automatically open during power failure (fail-safe) or stay closed (fail-secure)
DRIVE MECHANISM	Brushless Servo DC motor with planetary gearbox
OPENING SPEED	≤ 0.3 s and adjustable, Pass rate more than 35 p/m
MCBF	≥ 5 million cycles, MTTR ≤ 30 min
POWER SUPPLY	100–240 V AC, 50/60 Hz
WORKING VOLTAGE	36 V DC
POWER CONSUMPTION	≤ 260 W
OPERATING TEMPERATURE	–20°C to +55°C
HUMIDITY	≤ 95% (non-condensing)
INGRESS PROTECTION	IP42 (indoor use)
SIGNAL OUTPUT	NO/NC signal output for open/closed monitoring
OPTIONAL FEATURES	Multi-point infrared sensors and radar sensor module

## KEY HIGHLIGHTS

- Compact cylindrical design for premium environments
- Silent, smooth swing operation
- Customizable lane width and height accessibility
- Adjustable pass for pedestrian, wheelchair, cargo
- Environmental adaptability; outdoor with shelter
- Single or dual-lane configurations for wider passages
- Long service life with ≥ 10 million cycles for motor
- Forced Passage Protection, alarm, locked in small angle
- Special circuit module for breaking violence
- Without shacking by clutch specific output on driver
- Automatic one-time opening after power outage
- Sensor-less switch designed, homing automatically
- DIO 4/3 optocoupler isolated on the driver
- RS232/RS485/CAN bus on the driver
- Flexible barrier options (glass, acrylic, engraved)
- Optional sensors for prevent tailgating & piggybacking
- Optional battery backup in case of power failure

## INTEGRATION & CONTROL

- **Interfaces:** Two dry contacts for left / right opening, Status monitoring, Emergency exit, RS485, optional TCP/IP module.
- **Access Control Compatibility:** RFID, biometric, QR code, mobile credential reader, and third-party systems.
- **System Integration:** Compatible with viAccess and viBIO, REX-2 exit sensors, and EDR-3 emergency break-glass units.
- **Software Functions:** Control logic supports timed access, anti-passback, occupancy counting, and remote diagnostics.
- **Optional TCP/IP modules** allow centralized control and monitoring with cloud services.

## SAFETY & COMPLIANCE

- **Obstacle Detection:** Radar sensor prevents accidental contact with barriers. (Optional)
- **Fire Safety Mode:** Automatic opening during fire alarm or power outage.
- **Hardware Protection:** Under / over voltage protection, over current and over-temperature protection
- **Certifications:** CE, EN 61000-6-3 / EN 61000-6-1 (EMC compliance), RoHS, TUV
- **Ingress Protection:** IP42-rated for indoor use.

## DIMENSIONS

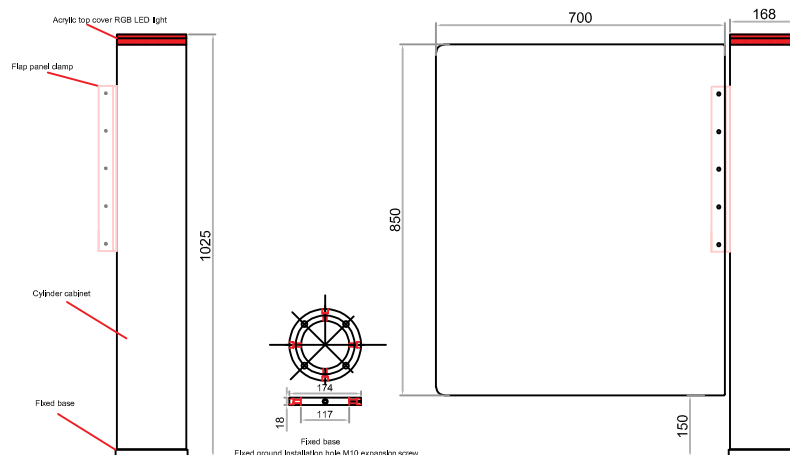

## PRODUCT WARRANTY

3-Years Limited Product Warranty  
Part Number: CSG301

All data contained herein subject to change without notice



### ABOUT VIMBERRY SECURITY SOLUTIONS

Vimberry Security Products markets high-quality security products via its worldwide offices and channel partners. Vimberry has offered high-quality systems for enterprise, small business, and residential applications. Our expansive product range features much more than access control solutions; we also offer applications software, Time & Attendance, and CCTV/alarm integration.